

Kinetics LV (low voltage 0,07kW-375kW)

Electric motors for standard and heavy duty operations-powerfull, efficient and flexible

Technical datasheet



SOLUTIONS FOR INDUSTRY

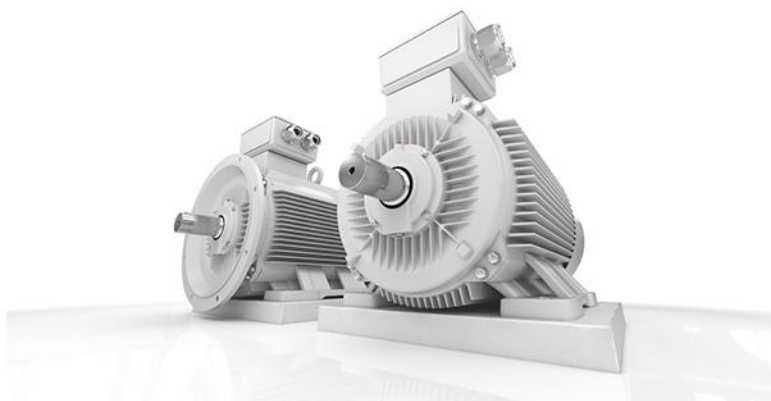

SOLUTIONS FOR INDUSTRY

Datasheet for three-phase motors

Motor type: 1LC180M-2, 22 kW

Electrical data

Power 50Hz (kW)	22,00
Power 60Hz (kW)	26,40
Frequency (Hz)	50/60
Voltage 50Hz (V)	400/690
Voltage 60Hz (V)	460/795
Voltage / frequency tolerance (invalid at range voltage)	Range B
Type of winding	Δ/Y
Number of poles	2
Efficiency 100% 50Hz (%)	91,3
Efficiency 75% 50Hz (%)	91,7
Efficiency 50% 50Hz (%)	89,5
Efficiency 100% 60Hz (%)	91,7
Efficiency 75% 60Hz (%)	91,7
Efficiency 50% 60Hz (%)	89,5
Power factor	0,88
Starting current (Ia/In)	8,2
Starting torque (Ma/Mn)	2,2
Breakdown torque (Mk/Mn)	2,3
Rated current 50Hz (A)	39,52/22,91

General data

Number of phases	3-
Type designation	1LC
Frame size	180
Type	B3
Housing design	M
Housing material	GG
Insulation class	F/B
Terminal box position	top
Terminal box Alignment	0 ° KV to the right
Weight (kg)	178,00
Direction of rotation	right/left
Vibration stage	A
Balancing	half key
Cooling type	IC411
Version according to	IEC 60034-1
Noise limit	IEC 60034-9

Mechanical data

Torque (Nm)	71,46/71,46
Speed (rpm)	2940/3528
Bearing (DE side)	6311.ZZ.C3
Bearing (NDE side)	6311.ZZ.C3
Bearing life (h)	20000
Permissible radial load (X/2) (N)	3300
Permissible radial load (X0) (N)	3675
Permissible radial load (Xmax) (N)	2925
Permissible axial load (N)	2900
Permissible axial load (V1) (N)	2800
Moment of inertia (kgm ²)	0,081

Factors

Operation mode	duty interval S1
Ambient temperature (°C)	-20 to +40
Installation height (m)	altitude up to 1000m

Motor characteristics

Painting	RAL7030
Paint surface	satin gloss
Protection class	IP55
Cable gland size (Cable)	2xM40x1,5
Cable gland size (option)	M20x1,5
Cable gland (type)	standard
Standard shaft end (mm)	48 x 110
Shaft material	C45

Additional option

Extra protection	PTC 150°C
------------------	-----------

Low Voltage induction motors electric motors

HIGH EFFICIENCY

RELIABLE OPERATION

2 LOAD CLASSES

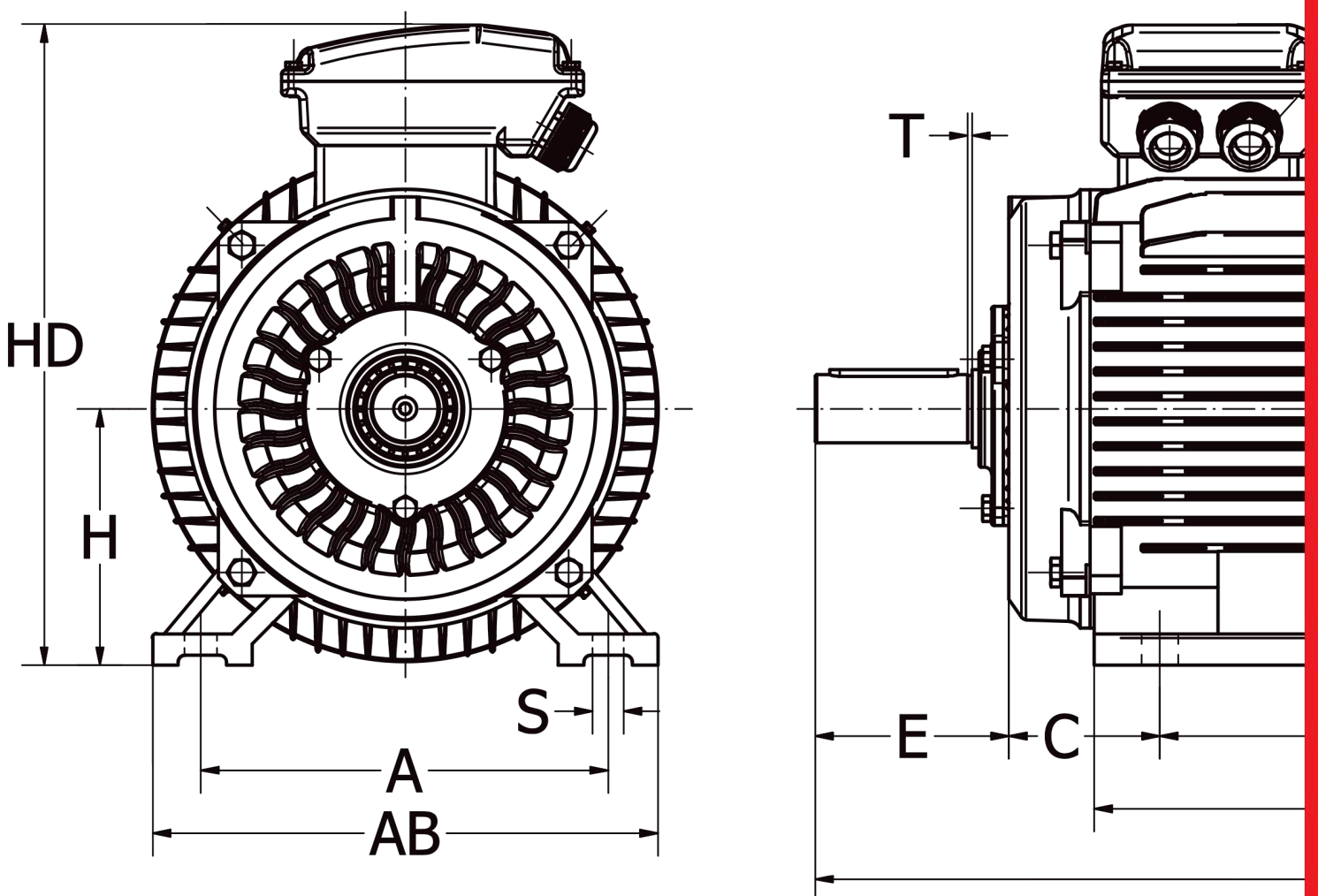

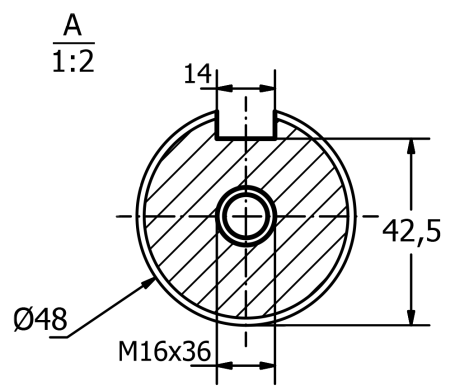
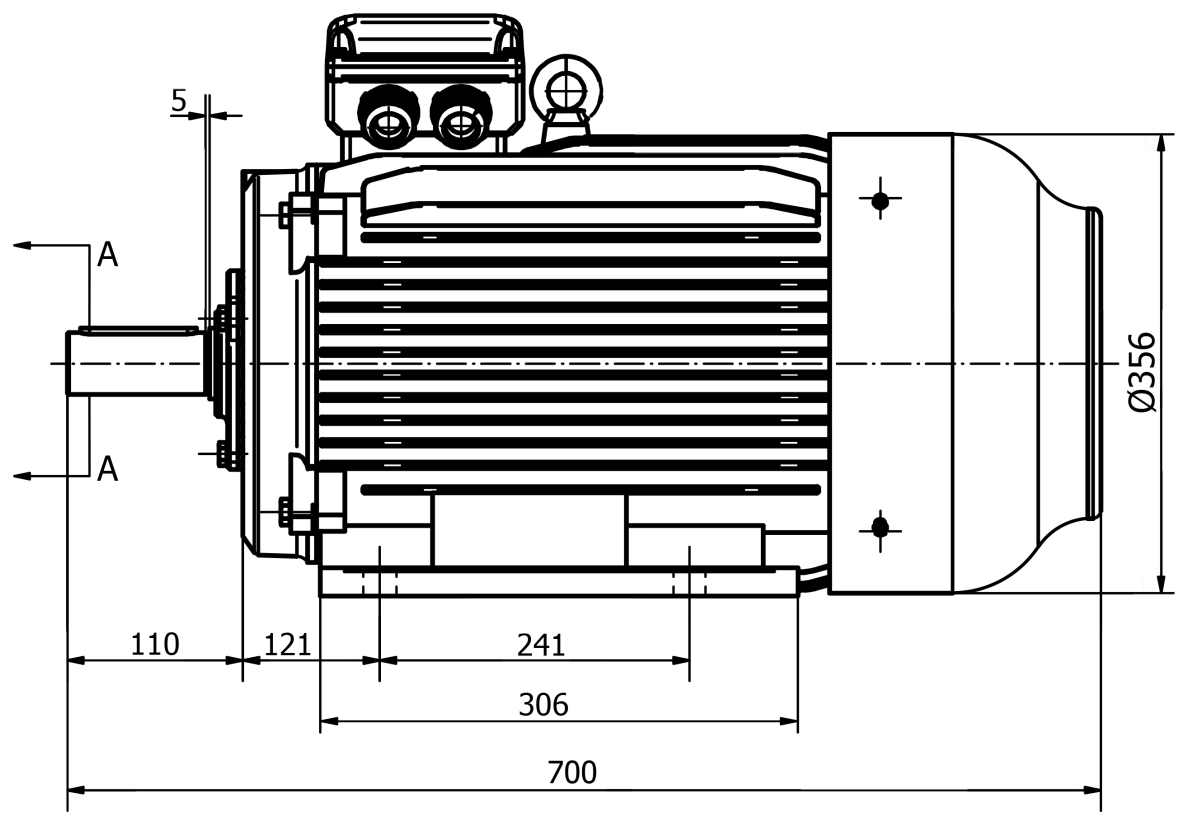
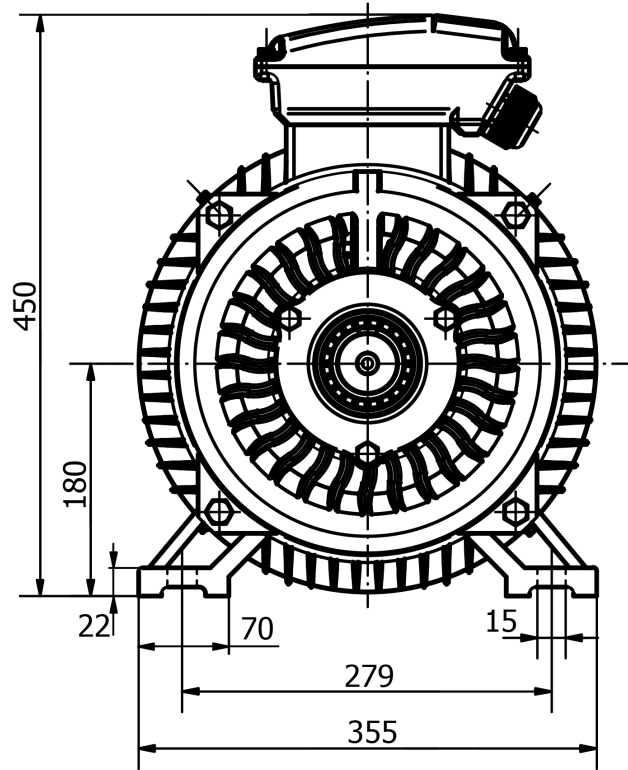

Vybo
Electric

1LC 180M B3

6 5 4 3 2 1

D

D

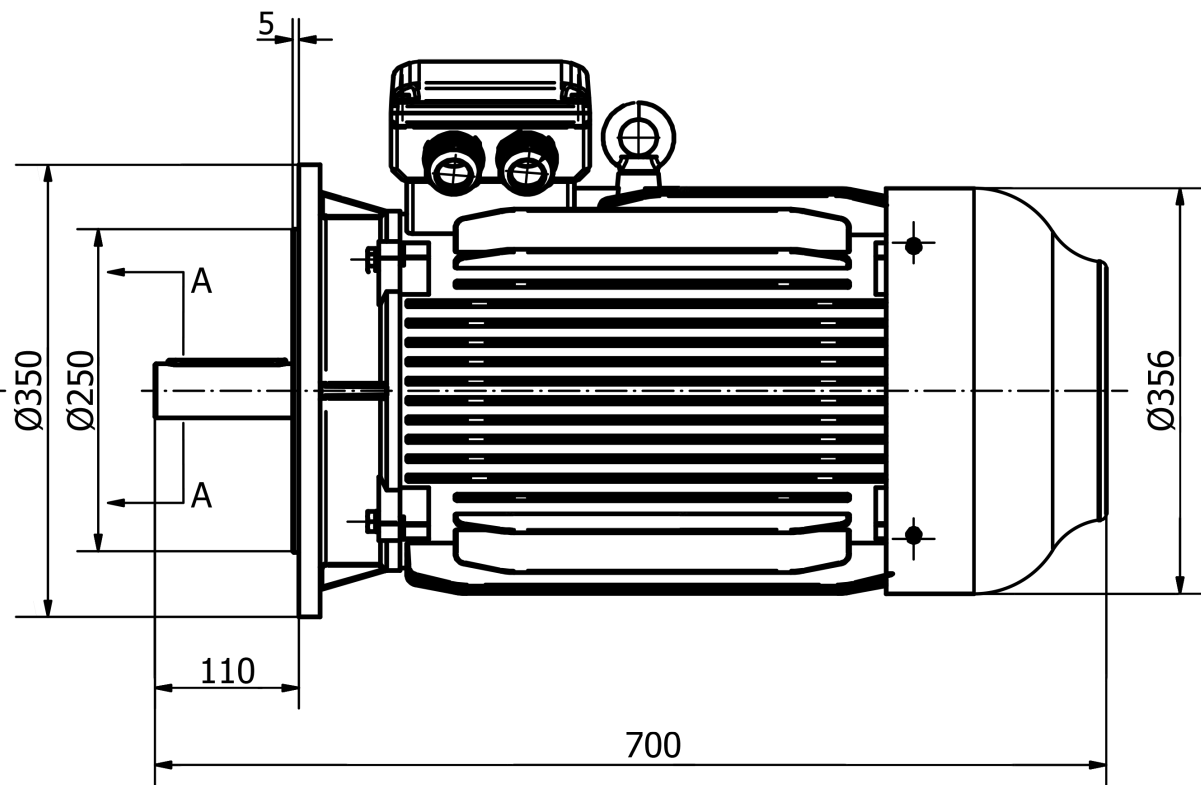
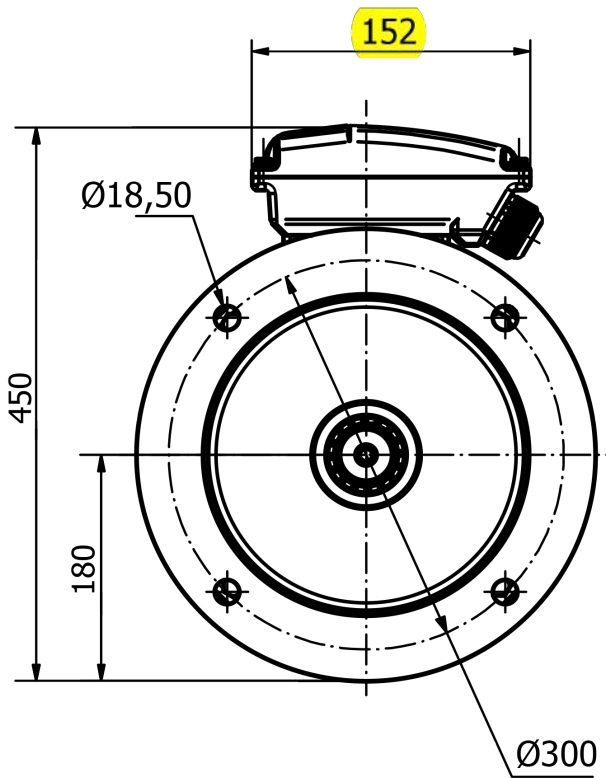

C

C

B

B

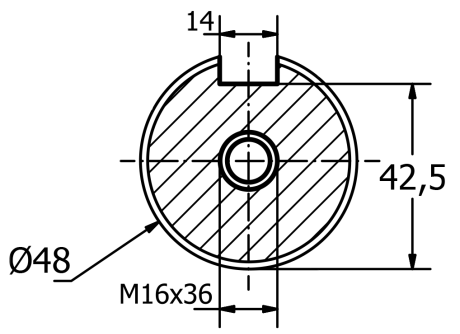

A

A

6 5 4 3 2 1

Vybo
Electric

1LC 180M B5

6 5 4 3 2 1

D

C

B

A

D

C

B

A

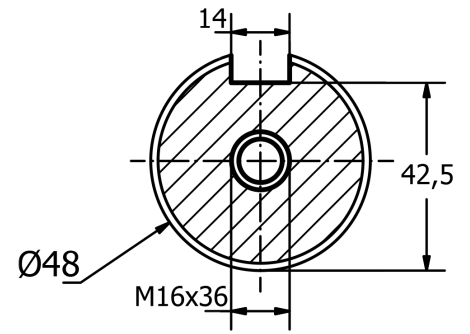
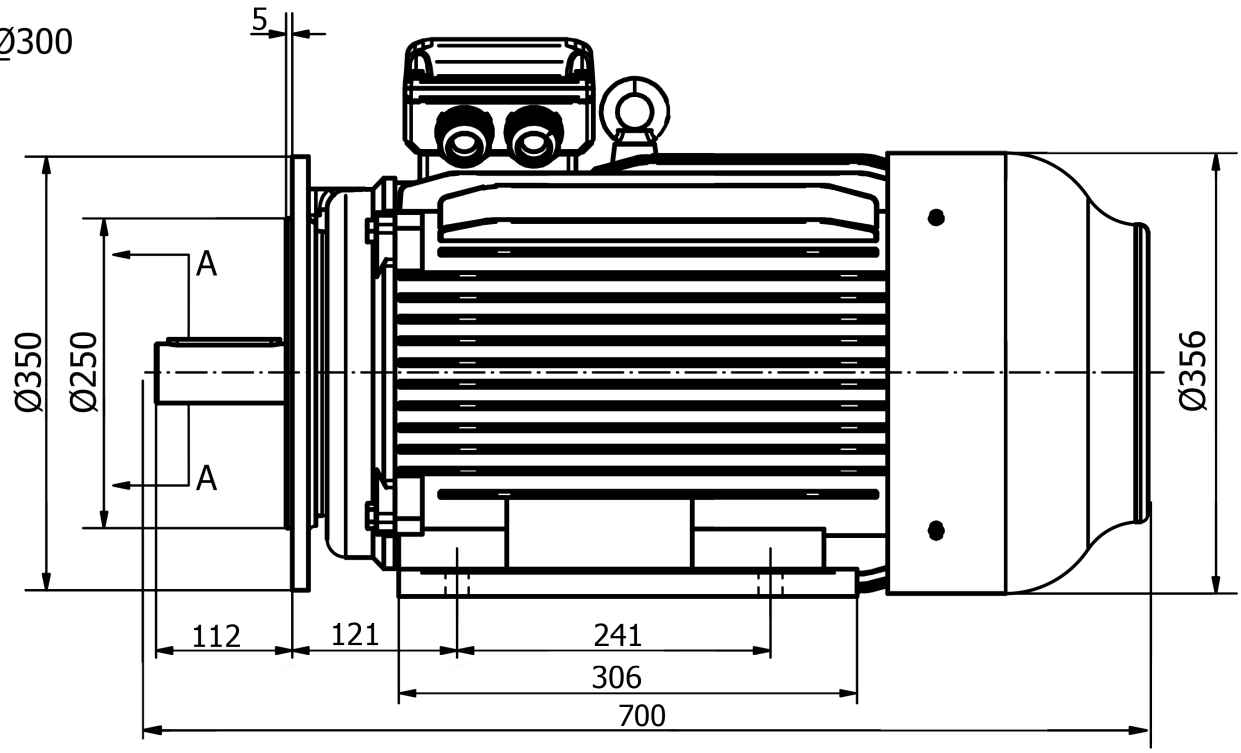
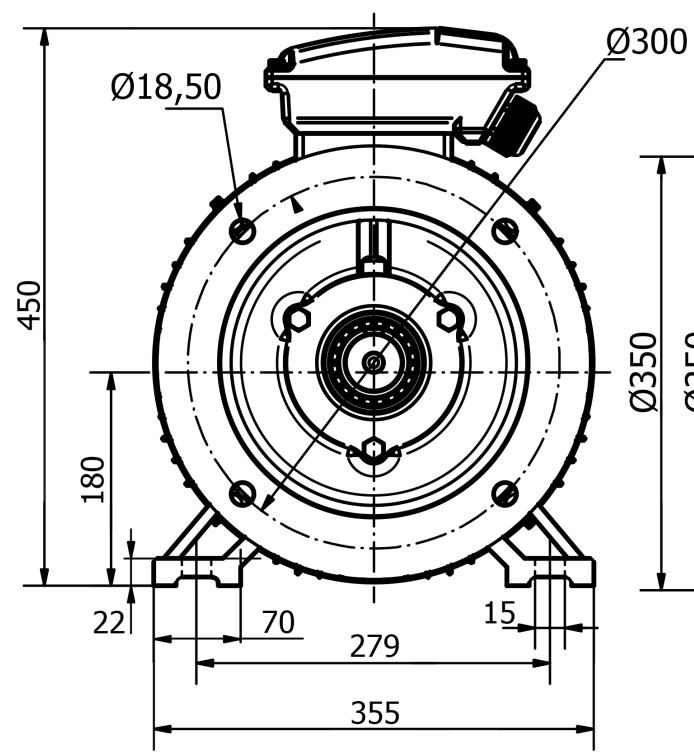

Vybo
Electric

1LC 180M B35

6 5 4 3 2 1



- | HIGH EFFICIENCY
- | RELIABLE OPERATION
- | 2 CLASSES OF LOADS

